

Total No. of Questions : 8]

SEAT No. :

P-9189

[Total No. of Pages : 3

[6179]-321

S.E. (Automobile & Mechanical/Automation & Robotics/Mechanical S.W)
KINEMATICS OF MACHINERY
(2019 Pattern) (Semester - IV) (202047)

Time : 2½ Hours]

[Max. Marks : 70

Instructions to the candidates:

- 1) Answer Q.1 or Q.2, Q.3 or Q.4, Q.5 or Q.6, Q.7 or Q.8.
- 2) Neat diagrams must be drawn whenever necessary.
- 3) Figures to the right indicate full marks.
- 4) Use of electronic non programmable calculator is allowed.
- 5) Assume suitable data if necessary.

Q1) a) Explain velocity image principle with neat sketch. [6]

b) The length of various links of mechanism as shown in figure are OA=0.3 m, AB=1 m, CD=0.8 m, AC=CB. The horizontal distance from point O and axis of vertical slider is 0.6 m. Determine for the given configuration [12]

- i) Velocity of slider B
- ii) Velocity of slider D
- iii) Angular velocity of CD
- iv) Angular velocity of AB

If OA rotates at 60 rpm clockwise use instantaneous centre method.

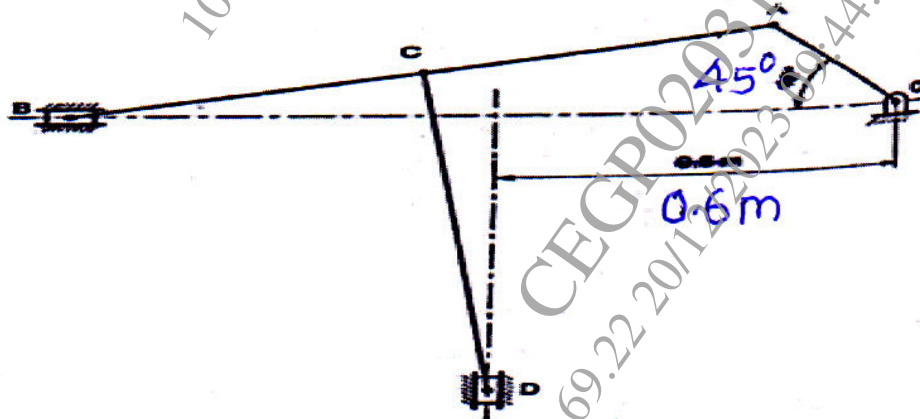

OR

P.T.O.

Q2) a) Explain with neat sketch Kennedy's theorem. [6]

b) In the mechanism shown, the slider D is constrained to move on a horizontal path. The crank OA is rotating at 180 rpm counter clockwise increasing at a rate of 50 rad/s². The dimensions of links are OA = 180 mm, CB = 240 mm, AB = 360 mm, BD = 540 mm. For the given configuration find [12]

- i) Velocity of slider D,
- ii) Angular velocity of links AB, CB and BD,
- iii) Angular acceleration of BD.

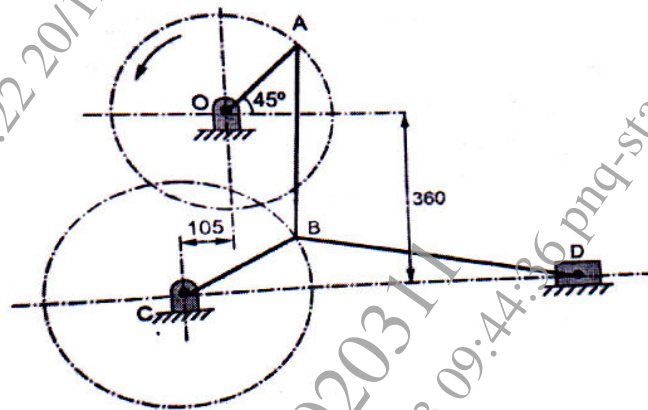

Q3) a) Explain with neat sketches three position synthesis of slider crank mechanism using relative pole method. [5]

b) Determine the Chebychev spacing for function $y = 2x^3 - x$ for the range of $0 \leq x \leq 4$ where four precision points are required. For three precision points determine [12]

$\theta_1, \theta_2, \theta_3$, and ϕ_1, ϕ_2, ϕ_3 if $\Delta\theta = 45^\circ$ and $\Delta\theta = 90^\circ$

OR

Q4) a) Explain in short : [6]

- i) Type synthesis,
- ii) Number synthesis,
- iii) Dimensional synthesis

b) Determine the Chebychev spacing for function $y = \log_{10} X$ for the range of $1 \leq x \leq 5$ where three precision points are required to be considered. [11]

- Q5) a)** Compare between Involute and Cycloidal gear tooth profile. [5]
- b)** Two mating gears have 20 and 40 involute teeth of module 10 mm and 20° pressure angle. The addendum on each wheel is to be made of such a length that the line of contact on each side of the pitch point has half the maximum possible length. Determine the addendum height for each gear wheel, length of the path of contact, arc of contact and contact ratio. [12]

OR

- Q6) a)** State and explain Law of gearing with neat sketch. [5]
- b)** Two involute gears in mesh have a module of 8mm and a pressure angle of 20° . The larger gear has 57 while pinion has 23 teeth. If addenda on pinion and gear wheels are equal to one module, Find contact ratio, angle of action of pinion and wheel, ratio of sliding to rolling velocity at beginning / end of contact and at pitch point. [12]

- Q7) a)** Define automation. Why automation is important for any industry? [5]

- b)** The following data relates to Knife Edge follower.

The follower to move outward through a distance of 20 mm during - 120°

The follower to dwell for the next - 60°

The follower to return to its initial position during - 90°

The follower to dwell for the remaining 90° of cam rotation.

The cam is rotating clockwise at a uniform speed of 500 rpm.

The minimum radius of the cam is 40 mm and line of stroke of the follower is offset 15 mm from the axis of the cam and displacement of the follower is to take place with uniform and equal acceleration and retardation both the inward and return stroke. [13]

OR

- Q8) a)** Write short note on : [5]

i) Assembly line balancing

ii) Buffer storages

- b)** A cam operates a roller, inline reciprocating follower while rotating at 300rpm. The further specifications are: Minimum radius of the cam=25mm, Lift of follower = 30mm, Diameter of roller =15mm Angle of lift = 120° (Nature of lift is S.H.M.), Outer dwell angle = 30° , Angle of return = 150° (Nature of return is uniform acceleration and retardation where acceleration is equal to retardation in magnitude). Draw the cam profile. [13]

